



## Power & Environmental Monitoring System for Data Centres, Server Rooms and Racks

iMeter is an advanced environmental and power monitoring solution that has been designed for use in Data Centres and Server Rooms. By combining power and environmental data users can prevent data centre disaster whilst also striving to make efficiency improvements in a safe and controlled manner.



The iMeter solution is made up of three principal components:

- iMeter Master Monitoring Device with 8 x Sensor Ports
- iMeter Slave Monitoring Device with 8 x Sensor Ports
- Jakarta Go-Probe Power & Environmental Sensors

The modular Master/Slave configuration provides users with the ability to monitor up to 496 x physical sensors from a single IP address. The system architecture allows for rapid deployment and easy expansion.

### Power Monitoring

The unique combination of power monitoring sensors on offer means that IT and Facilities personnel can analyse the relationships between power usage, airflow and temperature to help assist data centre management decisions relating to cost control and reduction. The design of the Jakarta Go-Probe sensors enables the complete system to be implemented with zero downtime. The IntelliAmp® current sensor can be clipped to the outside of 16 and 32 Amp power cables to monitor the True RMS current draw of single phase racks without any need to disrupt the power flowing into those racks.

### Environmental Monitoring

A variety of environmental sensors are available with the iMeter to ensure your data centre or racks are constantly monitored for potentially catastrophic events. Alerts can be delivered rapidly to IT and Facilities personnel via email, SNMP or SMS to ensure remedial action can be taken quickly. By responding quickly to potential environmental threats users have reported that they have seen a complete return on investment after just one alert and one disaster averted!

### Key Benefits

- Combine Environmental & Power sensors to create a single, central monitoring solution
- Monitor up-to 496 x Sensors, in any combination, from a single IP address
- Modular system for easy implementation and budget-matching
- Zero downtime required for installation
- Add custom maps for quick and easy identification of problems within your critical environments
- Integrate third-party equipment using SNMP and dry-contact interfaces to utilise iMeter alerting methods
- Quickly and easily compare power usage between data centre racks
- Evaluate power efficiency improvements over time
- Use iMeter on-board logs or iMS software to track power usage and environmental data for analysis
- 1-year warranty and free technical support via telephone & email

## iMeter Master & Slave

The iMeter Master module is a 1U rack-mountable Ethernet device with remote monitoring capability via its web browser interface, SNMP, Modbus and RS485. The device is equipped with 8 x sensor ports and 2 expansion ports for connection of iMeter Slave devices. Up-to 496 x Jacarta Go-Probe sensors can be monitored from a single IP address in conjunction with iMeter Slave modules. Each sensor input can also be configured to act as a dry-contact relay input/output for connection to third-party devices and onsite automation.

Each iMeter Slave provides 8 x sensor inputs/outputs and is equipped with daisy chain in and out ports for connection to the iMeter Master and/or further iMeter Slave devices using standard cat5 cable up-to 300m in length.



The screenshot shows the 'Jacarta iMeter Master' web interface. It features a navigation menu with 'Summary', 'Map', 'Sensors', 'Notification', 'Settings', and 'Help'. The main content area is divided into several sections: 'Sensor Filters' on the left, a central table of sensor information, and a 'System Log' at the bottom. The sensor table lists various sensors such as 'intelliAmp', 'Dual Temperature', and 'Humidity' across different racks, with columns for 'Board Name', 'Type', 'Sensor Name', 'Reading', and 'Status'. The system log shows a list of events with timestamps and descriptions, such as 'Rack Red 1 Front Door status is Normal'.

Board Name	Type	Sensor Name	Reading	Status
iMeter Master	intelliAmp	Server Rack Supply A	27.8 Amps	High Warning
	intelliAmp	Server Rack Supply B	27.1 Amps	High Warning
	Dual Temperature	Server Rack Temperature	27.8 °C	High Warning
	Humidity	Server Rack Humidity	22%	Normal
	intelliAmp	Telecomms Rack Supply A	26.3 Amps	Normal
	intelliAmp	Telecomms Rack Supply B	26.7 Amps	Normal
	Dual Temperature	Telecomms Temperature	27.8 °C	High Warning
	Humidity	Telecomms Humidity	28%	Normal

iMeter web-browser Interface - Comprehensive View



iMeter web-browser Interface - Map View

## Virtual Sensors

The iMeter also has a Virtual Sensor feature that allows the device to collect data from other devices via SNMP or ModBus. The iMeter has the capacity for up-to 80 x Virtual Sensors all of which utilise the same central notification system as physical sensors, meaning that alerts can be sent via Email, SNMP, SMS & Relay Output. Typical uses include:

- Gathering environmental data from other Jacarta devices to create a central monitoring and alerting hub
- Integrating existing SNMP-enabled systems such as UPS, VESDA and AC Units to monitor their status from a central location and utilise the iMeter alerting systems in the event of a problem
- Pinging other network hardware so that alerts can be sent out in the event of downtime

## Alerting Matrix

iMeter uses a powerful alert-management interface that enables notification routing to be tailored to all types of organisational requirements. Users can be alerted to problems via:

- Local on-screen alerts
- Email
- Alarm Beacon
- Dry-Contact Relay Output
- SNMPset commands
- SMS text messages (using optional modem)

The alerting matrix allows customised alerts to be sent to key personnel only when required. For example, if a temperature problem is experienced outside of office hours an alert can be sent directly to on-call staff. Users can also define custom escalation procedures helping to ensure that any threats to network infrastructure are dealt with before any serious problems are caused.

## Go-Probe Power and Environmental Sensors

The Jacarta range of Go-Probe sensors can be connected to each iMeter Master or iMeter Slave device in any combination to provide full flexibility for your power and environmental monitoring solution. Go-Probe Sensors include:

- intelliAmp Current Sensor (Amps)
- intelliAmp Voltage Sensor (Volts)
- Temperature/Humidity
- Airflow Sensor
- Water Leak Detector
- Smoke Detector
- Security Sensor (door open)
- Motion Sensor (PIR)

## intelliAmp Current Sensor



The remarkable intelliAmp Current Sensor has been designed to monitor the current draw of racks via 16A and 32A cables. The sensor contains a unique calibration mechanism to enable it to be positioned at the point where the optimal current reading can be obtained. The fact that the sensor simply clips to the cable means no network downtime is required to start monitoring your racks.

## intelliVolt Voltage Sensor

The intelliVolt voltage sensor simply connects into one of the iMeter sensor ports and plugs into a mains outlet. Voltage is monitored between 0 and 265v. High and Low threshold settings can be user configured on the iMeter to ensure alarm notification during over or under voltage conditions.



## Go-Probe Environmental Sensors

### Temperature and Humidity Sensor

The combined Temperature & Humidity sensor is small and discreet and allows you to monitor both environmental conditions using a single sensor input. The sensor can be provided with a waterproof housing for use in harsh environments.

### Water Detector

The Water Detector uses an advanced leak detection cable to sense the presence of water along its length. The water detector can be custom-built with up-to 30m of water detecting sensor cable and up-to 30m of interface cable.

### Security Sensor

The Security Sensor is a magnetic reed switch that can be used to detect the opening of doors, racks, windows and cupboards. A time delay can be added to the alarm so that an alert is only sent if a door/window is left open beyond a certain amount of time.

### Dry-Contact Cable

Connect the iMeter to any third-party device where dry-contact outputs are available. These cables are typically used to connect to on-site systems such as UPS, VESDA, BMS Systems and AC Units.

### Smoke Detector

The Smoke Detector is a mains powered, ionisation based smoke detection unit that can be positioned to monitor for early signs of fire, triggering an iMeter alert and an audible alarm upon detection.

### Also available...

- Motion Detection
- Airflow
- Power Failure

*All Go-Probe Sensors are manufactured in the UK and can be built with custom interface cable lengths (up-to 30m) to suit your requirement.*

Sensors can be connected to the iMeter Master and Slave devices in any combination. The following diagram highlights the potential sensor capacity and flexibility of the iMeter:

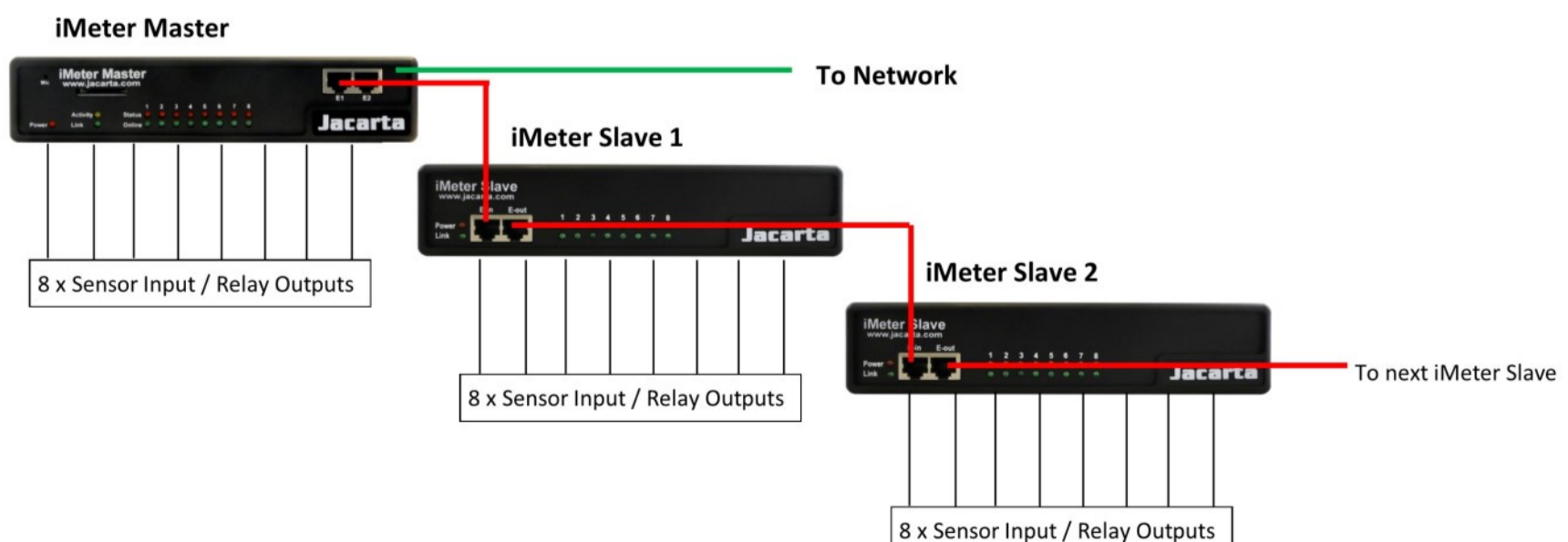

## iMeter Master—Specifications

- Sensors: 8 x RJ45 Auto detecting ports (Up-to 496 • Jakarta Go-Probe sensors can be monitored from a single IP address in conjunction with iMeter Slave modules)
- Relay Outputs: Any RJ45 sensor port can be configured as a relay
- Optional Equipment: - iMeter Slave: 8x RJ45 sensor ports  
- GSM Modem
- Network: 10/100Mbps Ethernet (auto-sense)
- Status Indicators: Sensor online and status LED, Power LED, 10/100 LED
- Configuration: Browser, Modbus
- Monitoring: Browser, NMS
- Alerts: Email, SNMP traps, Voice and SMS via optional additional GSM USB Modem
- Alert Configuration: 1. Temperature/Humidity: High/low warning and critical thresholds (user configurable)  
2. Go-Probe Sensors: Normally open/closed or high/low active (user configurable)  
3. intelliAmp/intelliVolt: High/low warning and critical thresholds (user configurable)
- Logging: Event, Status and configuration
- Graphs: Real-time and historical
- Graphs Interval: Daily, Weekly, Monthly and Yearly
- Firmware Upgrade: Via Network Connection
- System Security: IP based filtering and password protection
- Weight (kg): 1.09
- Dimensions (cm): 4.6 (h) x 21.6 (w) x 13.8 (d)
- Power: 7.5VDC PSU supplied
- Warranty: 1 Year

## iMeter Slave—Specifications

- Sensors: 8x RJ45 Auto detecting ports.
- Relay Outputs: Any RJ45 sensor port can be configured as a relay
- Optional Equipment: iMeter Slave: 8 x RJ45 sensor ports
- Link Distance: Up to 300m
- Configuration: Via iMeter Master
- Monitoring: Via iMeter Master
- Dimensions (cm): 4.6 (h) x 21.6 (w) x 13.8 (d)
- Weight (kg): 1.09
- Power: 7.5VDC PSU supplied
- Status Indicators: Sensor online and status LED, Power LED, Link LED
- Warranty: 1 Year

